

N2S065006PA2

Silicon Carbide Schottky Diode

| | | |
|-----------------------------------|---|------|
| V_{RRM} | = | 650V |
| $I_F(T_C \leq 135^\circ\text{C})$ | = | 11A |
| Q_c | = | 17nC |

Features

- New Thin Wafer Technology
- Low Forward Voltage Drop (V_F)
- Zero Reverse Recovery Current
- Zero Forward Recovery Voltage
- Positive Temperature Coefficient on V_F
- Temperature-independent Switching

Benefits

- Replace Bipolar with Unipolar Device
- Reduction of Heat Sink Size
- Parallel Devices Without Thermal Runaway
- Essentially No Switching Losses

Applications

- Switch Mode Power Supplies
- Uninterruptible Power Supplies
- Motor drive, PV Inverter, Wind Power Station

Package

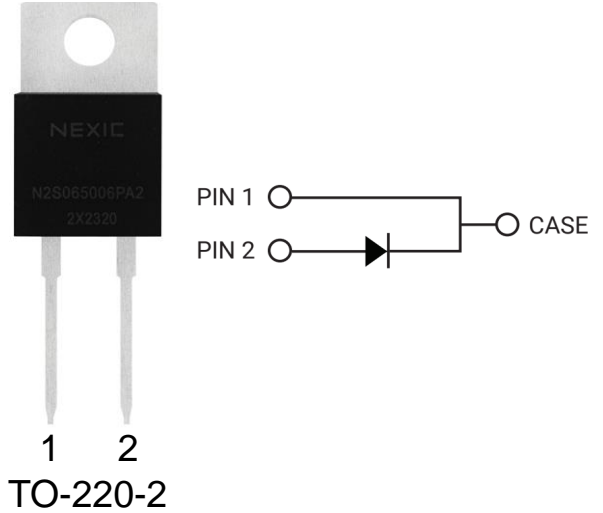

| Part Number | Package | Marking |
|--------------|----------|--------------|
| N2S065006PA2 | TO-220-2 | N2S065006PA2 |

Maximum Ratings

| Symbol | Parameter | Value | Unit | Test Conditions | Note |
|----------------|--|------------|------------------|--|-------|
| V_{RRM} | Repetitive Peak Reverse Voltage | 650 | V | $T_C = 25^\circ\text{C}$ | |
| V_{RSM} | Surge Peak Reverse Voltage | 650 | V | $T_C = 25^\circ\text{C}$ | |
| V_R | DC Blocking Voltage | 650 | V | $T_C = 25^\circ\text{C}$ | |
| I_F | Forward Current | 25 | A | $T_C \leq 25^\circ\text{C}$ | |
| | | 11 | | $T_C \leq 135^\circ\text{C}$ | |
| | | 6 | | $T_C \leq 156^\circ\text{C}$ | |
| I_{FSM} | Non-Repetitive Forward Surge Current | 52 | A | $T_C = 25^\circ\text{C}$, $t_p = 8.3\text{ms}$, Half Sine Wave | |
| P_{tot} | Power Dissipation | 83 | W | $T_C = 25^\circ\text{C}$ | Fig.3 |
| T_J, T_{STG} | Operating Junction and Storage Temperature | -55 to 175 | $^\circ\text{C}$ | | |

Electrical Characteristics

| Symbol | Parameter | Typ. | Max. | Unit | Test Conditions | Note |
|--------|-------------------------|-----------------|------------|---------|--|-------|
| V_F | Forward Voltage | 1.27 1.38 | 1.5 1.6 | V | $I_F = 6A, T_J = 25^\circ C$ $I_F = 6A, T_J = 175^\circ C$ | Fig.1 |
| I_R | Reverse Current | 4 20 | 50 200 | μA | $V_R = 650V, T_J = 25^\circ C$ $V_R = 650V, T_J = 175^\circ C$ | Fig.2 |
| C | Total Capacitance | 380 39 28 | / | pF | $V_R = 0V, T_J = 25^\circ C, f = 1MHz$ $V_R = 200V, T_J = 25^\circ C, f = 1MHz$ $V_R = 400V, T_J = 25^\circ C, f = 1MHz$ | Fig.5 |
| Q_C | Total Capacitive Charge | 17 | / | nC | $V_R = 400V, I_F = 6A$ $di/dt = 200A/\mu s, T_J = 25^\circ C$ | Fig.4 |

Thermal Characteristics

| Symbol | Parameter | Typ. | Unit | Note |
|-----------------|---|------|--------------|-------|
| $R_{\theta JC}$ | Thermal Resistance from Junction to Case | 1.8 | $^\circ C/W$ | Fig.6 |
| $R_{\theta JA}$ | Thermal Resistance from Junction to Ambient | 80 | $^\circ C/W$ | |
| T_{sold} | Soldering Temperature | 260 | $^\circ C$ | |

Typical Performance

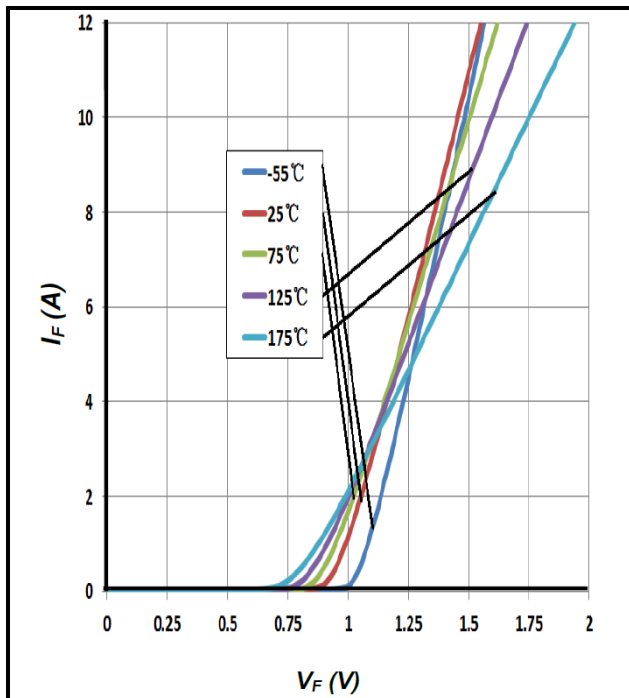

Figure 1. Forward Characteristics

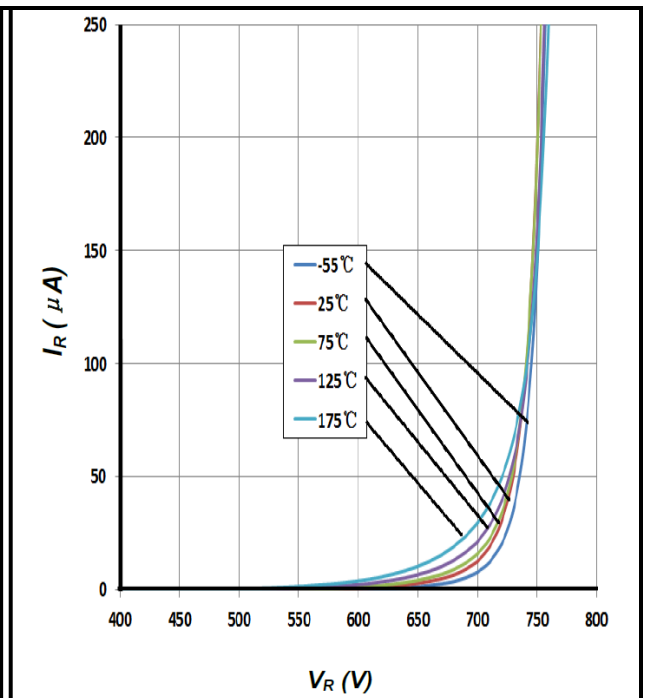

Figure 2. Reverse Characteristics

Typical Performance

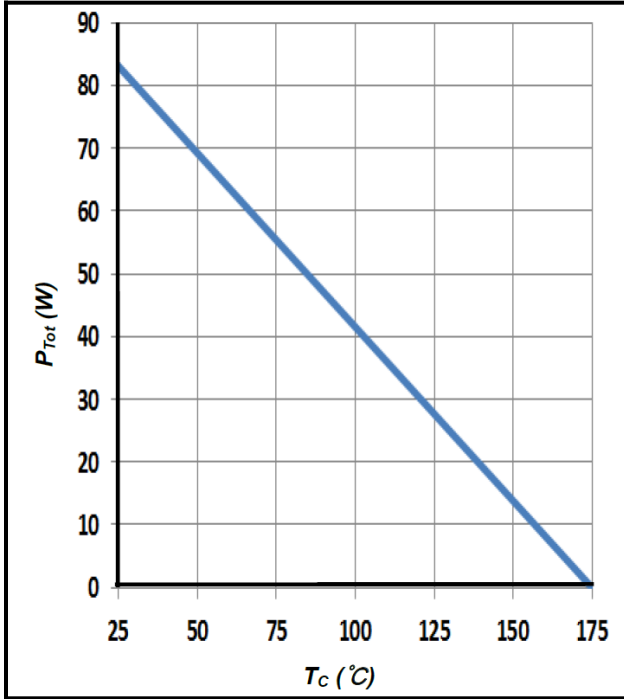

Figure 3. Power Derating

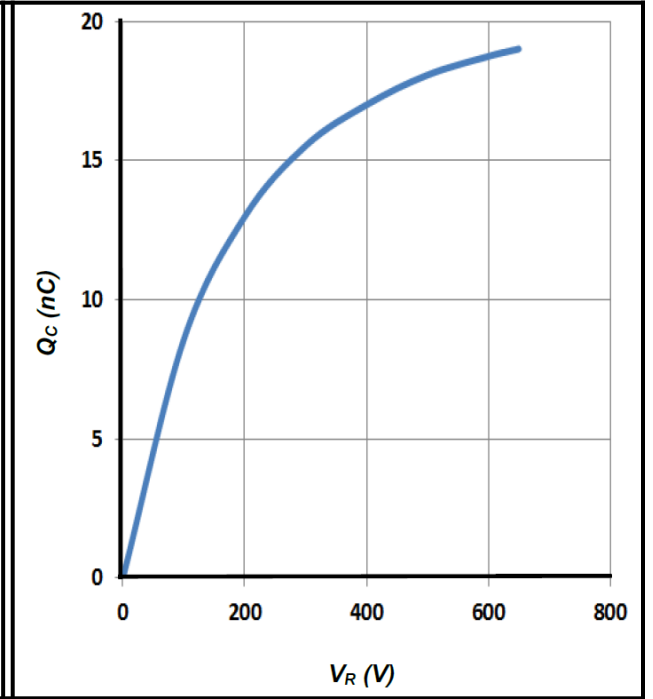

Figure 4. Total Capacitive Charge vs. Reverse Voltage

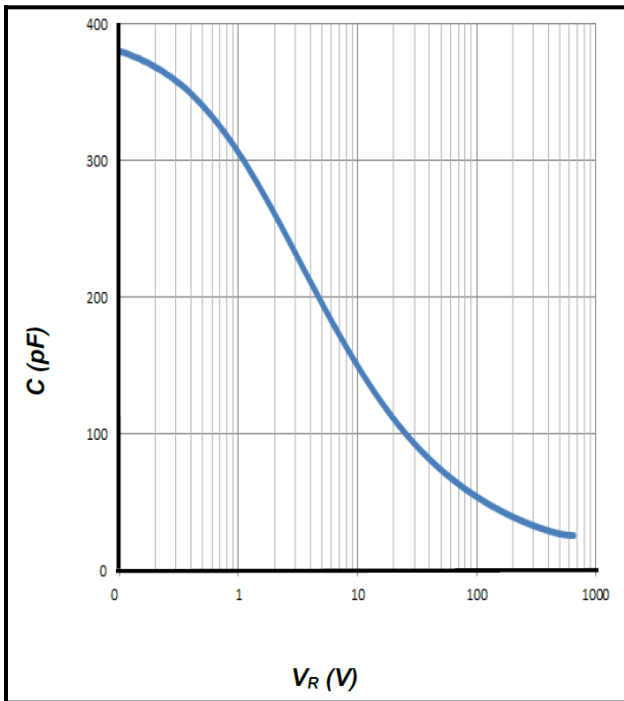

Figure 5. Total Capacitance vs. Reverse Voltage

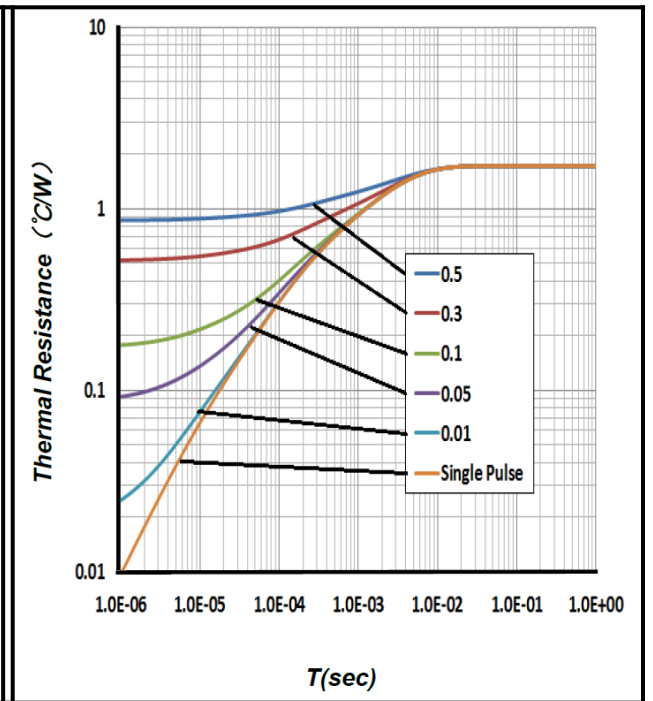
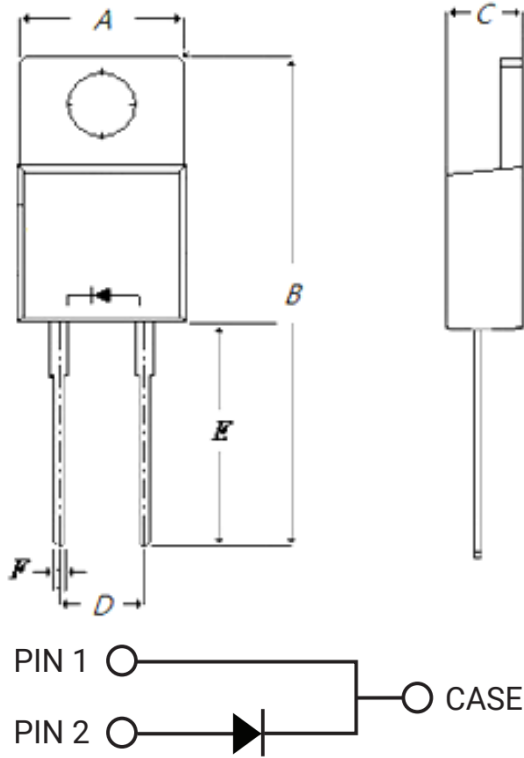

Figure 6. Transient Thermal Impedance

Package Dimensions

Package TO-220-2



| SYMBOL | mm | | |
|--------|-------|-------|-------|
| | MIN | NOM | MAX |
| A | 9.17 | 10.08 | 10.91 |
| B | 27.00 | 28.58 | 30.00 |
| C | 3.89 | 4.50 | 5.00 |
| D | 4.20 | 5.10 | 5.80 |
| E | 11.70 | 13.30 | 14.97 |
| F | 0.50 | 0.80 | 1.21 |

Simplified Diode Model

Equivalent IV Curve for Model

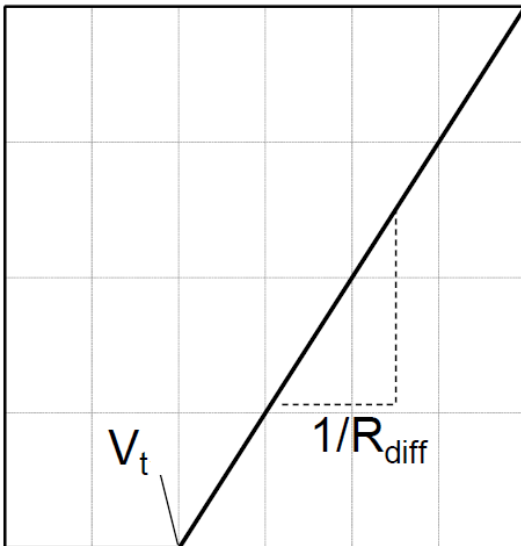

Mathematical Equation

$$V_F = V_t + I_F \times R_{diff}$$

$$V_t = -0.001 \times T_j + 0.99 \text{ [V]}$$

$$R_{diff} = 1.2 \times 10^{-6} \times T_j^2 + 7.2 \times 10^{-5} \times T_j + 0.46 \text{ [\Omega]}$$

Note:

T_j = Diode Junction Temperature In Degrees Celsius, valid from 25°C to 175°C

I_F = Forward Current Less than 12A